

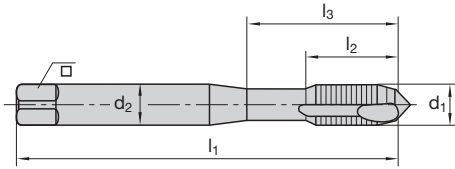

DIN 371

DIN 376



Katalog-Nr. Cat.-No.									6411		6412	
P1	Stahl Steel < 500 N/mm ²								<input type="checkbox"/>	v _c = 10–15 m/min	<input type="checkbox"/>	v _c = 10–15 m/min
P2	Stahl Steel 500–1000 N/mm ²								<input type="checkbox"/>	v _c = 10–15 m/min	<input type="checkbox"/>	v _c = 10–15 m/min
P3	Stahl Steel > 1000 N/mm ²											
M1	Rostfreie austenitische Stähle Stainless steel austenitic											
M2	Rostfreie martensitische Stähle Stainless steel martensitic											
K1	Grauguss Grey cast iron											
K2	Sphäroguss Nodular cast iron								<input type="checkbox"/>	v _c = 10–15 m/min	<input type="checkbox"/>	v _c = 10–15 m/min
N1	Alu- & Cu-Legierungen langspanend Alu- & Copper alloys long chipping < 5 % Si											
N2	Alu- & Cu-Legierungen langspanend Alu- & Copper alloys long chipping 5–10 % Si											
N3	Alu- & Cu-Legierungen kurzspanend Alu- & Copper alloys short chipping > 10 % Si								<input type="checkbox"/>	v _c = 10–15 m/min	<input type="checkbox"/>	v _c = 10–15 m/min
N4	Graphit Graphite											
S1	Titanlegierungen mittelfest Titanium alloys medium strength < 900 N/mm ²											
S2	Titanlegierungen hochfest Titanium alloys high strength < 1300 N/mm ²											
H1	Hartguss und Harte Stähle Chilled steel and Hardened steel 45–55 HRC											
d ₁	P	l ₁	l ₂	l ₃	d ₂	<input type="checkbox"/> h12	z		Ident No.	LMT-Code	Ident No.	LMT-Code
mit verstärktem Zylinderschaft with reinforced straight shank												
M 2	0,4	45	5	11	2,8	2,1	3	1,6	1393714	TC-BM 02x0.40-6H-V0-0	–	–
M 2,2	0,45	45	5	12	2,8	2,1	3	1,75	1393715	TC-BM 2.2x0.45-6H-V0-0	–	–
M 2,3	0,4	45	5	13	2,8	2,1	3	1,9	1393716	TC-BM 2.3x0.40-6H-V0-0	–	–
M 2,5	0,45	50	5	15	2,8	2,1	3	2,05	1393717	TC-BM 2.5x0.45-6H-V0-0	–	–
M 2,6	0,45	50	5	16	2,8	2,1	3	2,1	1393718	TC-BM 2.6x0.45-6H-V0-0	–	–
M 3	0,5	56	5	18	3,5	2,7	3	2,5	1393719	TC-BM 03x0.50-6H-V0-0	–	–
M 3,5	0,6	56	6	20	4	3	3	2,9	1393731	TC-BM 3.5x0.60-6H-V0-0	–	–
M 4	0,7	63	7	21	4,5	3,4	3	3,3	1393728	TC-BM 04x0.70-6H-V0-0	–	–
M 5	0,8	70	8	25	6	4,9	3	4,2	1393737	TC-BM 05x0.80-6H-V0-0	–	–
M 6	1	80	10	30	6	4,9	3	5	1393746	TC-BM 06x1.00-6H-V0-0	–	–
M 7	1	80	10	30	7	5,5	3	6	1393747	TC-BM 07x1.00-6H-V0-0	–	–
M 8	1,25	90	13	35	8	6,2	3	6,8	1393755	TC-BM 08x1.25-6H-V0-0	–	–
M 10	1,5	100	15	39	10	8	3	8,5	1393764	TC-BM 10x1.50-6H-V0-0	–	–
mit Überlaufschaft with standard straight shank												
M 3	0,5	56	6	–	2,2	1,2	3	2,5	–	–	1393751	TC-BM 03x0.50-6H-V0-0
M 4	0,7	63	7	–	2,8	2,1	3	3,3	–	–	1393752	TC-BM 04x0.70-6H-V0-0
M 5	0,8	70	8	–	3,5	2,7	3	4,2	–	–	1393768	TC-BM 05x0.80-6H-V0-0
M 6	1	80	10	–	4,5	3,4	3	5	–	–	1393769	TC-BM 06x1.00-6H-V0-0
M 8	1,25	90	14	–	6	4,9	3	6,8	–	–	1393770	TC-BM 08x1.25-6H-V0-0
M 10	1,5	100	16	–	7	5,5	3	8,5	–	–	1393771	TC-BM 10x1.50-6H-V0-0
M 12	1,75	110	18	–	9	7	3	10,2	–	–	1393773	TC-BM 12x1.75-6H-V0-0
M 14	2	110	20	–	11	9	3	12	–	–	1393782	TC-BM 14x2.00-6H-V0-0
M 16	2	110	20	–	12	9	3	14	–	–	1393791	TC-BM 16x2.00-6H-V0-0

 Kernlochbohrer ab Seite 367
 Pre-drills starting page 367

 ■ = Hauptanwendung First choice
 □ = Nebenanwendung Second choice

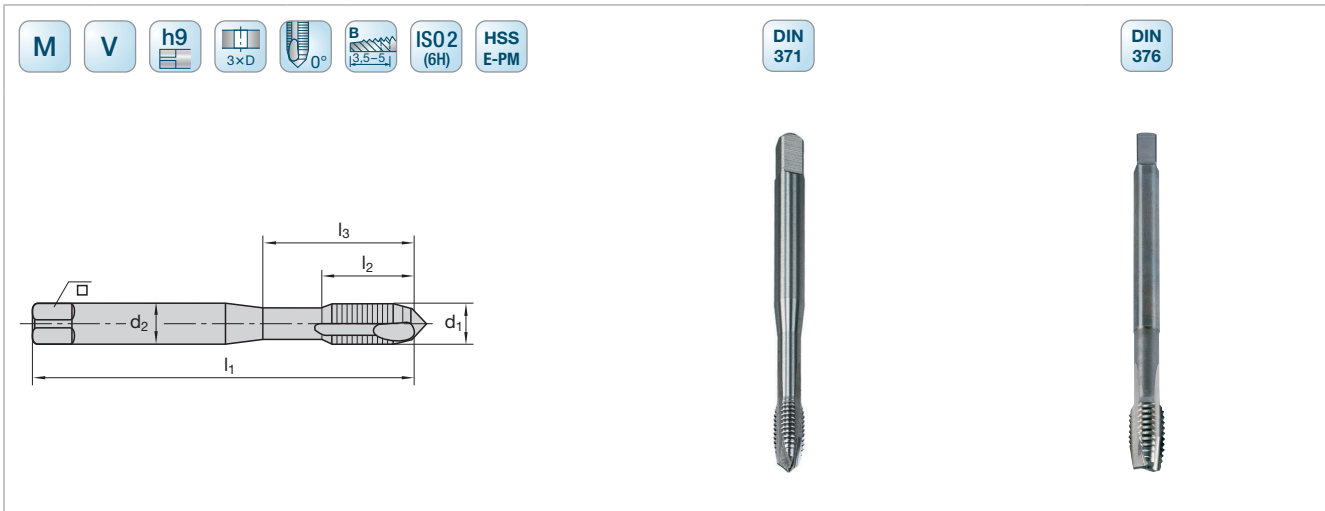
Katalog-Nr. Cat.-No.									6411			6412
P1	Stahl Steel < 500 N/mm ²								<input type="checkbox"/> v _c = 10–15 m/min			<input type="checkbox"/> v _c = 10–15 m/min
P2	Stahl Steel 500–1000 N/mm ²								<input type="checkbox"/> v _c = 10–15 m/min			<input type="checkbox"/> v _c = 10–15 m/min
P3	Stahl Steel > 1000 N/mm ²											
M1	Rostfreie austenitische Stähle Stainless steel austenitic											
M2	Rostfreie martensitische Stähle Stainless steel martensitic											
K1	Grauguss Grey cast iron											
K2	Sphäroguss Nodular cast iron								<input type="checkbox"/> v _c = 10–15 m/min			<input type="checkbox"/> v _c = 10–15 m/min
N1	Alu- & Cu-Legierungen langspanend Alu- & Copper alloys long chipping < 5 % Si											
N2	Alu- & Cu-Legierungen langspanend Alu- & Copper alloys long chipping 5–10 % Si											
N3	Alu- & Cu-Legierungen kurzspanend Alu- & Copper alloys short chipping > 10 % Si								<input type="checkbox"/> v _c = 10–15 m/min			<input type="checkbox"/> v _c = 10–15 m/min
N4	Graphit Graphite											
S1	Titanlegierungen mittelfest Titanium alloys medium strength < 900 N/mm ²											
S2	Titanlegierungen hochfest Titanium alloys high strength < 1300 N/mm ²											
H1	Hartguss und Harte Stähle Chilled steel and Hardened steel 45–55 HRC											
d ₁	P	l ₁	l ₂	l ₃	d ₂	<input type="checkbox"/> h12	z		Ident No.	LMT-Code	Ident No.	LMT-Code
mit Überlaufschaft with standard straight shank												
M 18	2,5	125	25	–	14	<input type="checkbox"/>	3	15,5	–	–	1393808	TC-BM 18x2.50-6H-V0-0
M 20	2,5	140	25	–	16	<input type="checkbox"/>	3	17,5	–	–	1393817	TC-BM 20x2.50-6H-V0-0
M 22	2,5	140	25	–	18	<input type="checkbox"/>	3	19,5	–	–	1384583	TC-BM 22x2.50-6H-V0-0
M 24	3	160	30	–	18	<input type="checkbox"/>	4	21	–	–	1384584	TC-BM 24x3.00-6H-V0-0
M 27	3	160	30	–	20	<input type="checkbox"/>	4	24	–	–	1384586	TC-BM 27x3.00-6H-V0-0
M 30	3,5	180	35	–	22	<input type="checkbox"/>	4	26,5	–	–	1384588	TC-BM 30x3.50-6H-V0-0
M 36	4	200	40	–	28	<input type="checkbox"/>	4	32	–	–	1384590	TC-BM 36x4.00-6H-V0-0
M 42	4,5	220	45	–	32	<input type="checkbox"/>	4	37,5	–	–	1384592	TC-BM 42x4.50-6H-V0-0
M 45	4,5	220	56	–	36	<input type="checkbox"/>	4	40,5	–	–	9127694	TC-BM 45x4.50-6H-V0-0
M 48	5	250	63	–	36	<input type="checkbox"/>	4	43	–	–	9127706	TC-BM 48x5.00-6H-V0-0
M 52	5	250	63	–	40	<input type="checkbox"/>	4	47	–	–	9127711	TC-BM 52x5.00-6H-V0-0

Kernlochbohrer ab Seite 367
Pre-drills starting page 367

■ = Hauptanwendung First choice
□ = Nebenanwendung Second choice