

Fräsköpfe 90° für NE-Metalle und Kunststoffe
Milling cutters 90° for non-ferrous metals and plastics

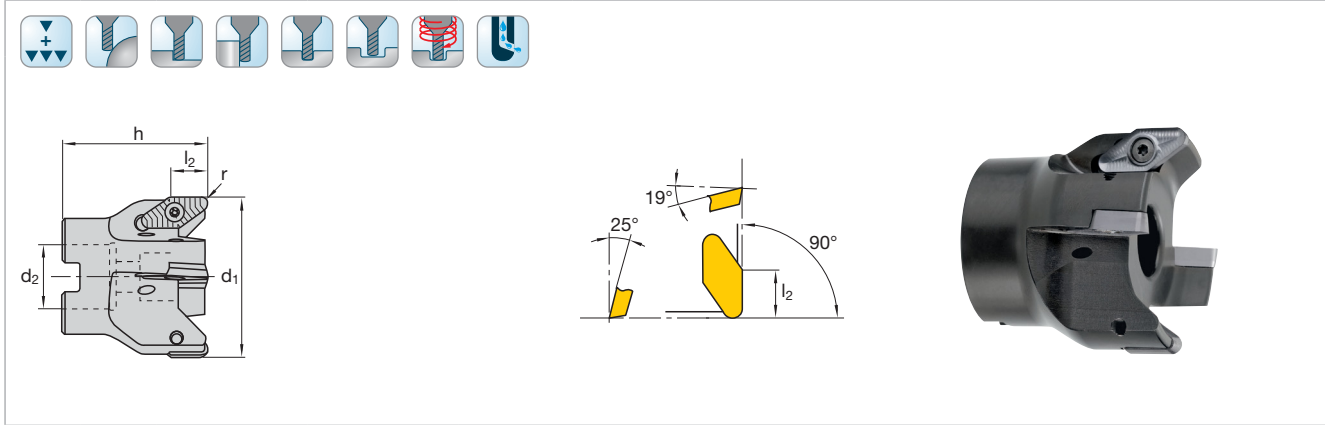

Katalog-Nr. Cat.-No.							FMZ 90 IK				
d ₁	r	l ₂	h	d ₂	z	Ident No.	LMT-Code				
42	3	15	55	16	3	1043253	FMZ90 V22.042AN-I	VCGT 220530-ALM	1045766	1048335 T15	
52	3	15	55	22	3	1043254	FMZ90 V22.052AN-I				
66	3	15	60	27	4	1043255	FMZ90 V22.066AN-I				
80	3	15	60	27	4	1043256	FMZ90 V22.080AN-I				
100	3	15	65	32	5	1043257	FMZ90 V22.100AN-I				
125	3	15	65	40	6	1043258	FMZ90 V22.125AN-I				

Fräser auch verfügbar in Zoll-Abmessungen
 Cutters also available in inch dimensions

Schnittwertempfehlungen ab Seite 338
 Cutting data recommendations starting page 338

Wendeschneidplatten für Fräskopf 90° für NE-Metalle und Kunststoffe
Indexable inserts for milling cutters 90° for non-ferrous metals and plastics

N = Anzahl der Schneidkanten N = Number of cutting edges	LMT-Code	l	d	s	d ₁	r	Schneidstoffsorten Cutting materials Ident No.										Für Fräser For cutter	
							LC280QN	LC240Q	LC240T	LC225T	LC630Q	LC440T	LCM40M	LCM44M	LC444W	LCK10M	LC610Q	LC610T
 N = 2	VCGT 220530 ALM	22,1	12,7	5,56	5,5	3										1069760	1069759	EMZ90 FMZ90
	VPGT 160412 ALM	16,6	12,7	4,76	4,4	1,2									1069758	1069757		

■ = Hauptanwendung First choice
 □ = Nebenanwendung Alternative

Sortenbeschreibung/-bezeichnung und ISO-Code ab Seite 354/420
 Description/Designation of grades and ISO-Code starting page 354/420

P	M	K	N	S	H
			■	■	

Fräsen mit Wendeschneidplatten
 Milling with indexable inserts