

Katalog-Nr. Cat.-No.									EMZ 90 THR IK			
d ₁	r	l ₂	l ₃	d ₅	d ₃	d ₂	z	Ident No.	LMT-Code			
25	1,2	13,5	40	21	M12	12,5	2	1043247	EMZ90 V16.025TF040-I	VPGT 160412-ALM	1051312	1048335
32	3	15	50	29	M16	17	2	1043248	EMZ90 V22.032TH050-I	VCGT 220530-ALM	1045766	T15
42	3	15	50	29	M16	17	3	1043249	EMZ90 V22.042TH050-I			

Fräser auch verfügbar in Zoll-Abmessungen
 Cutters also available in inch dimensions

Schafffräser 90° für NE-Metalle und Kunststoffe
End mills 90° for non-ferrous metals and plastics

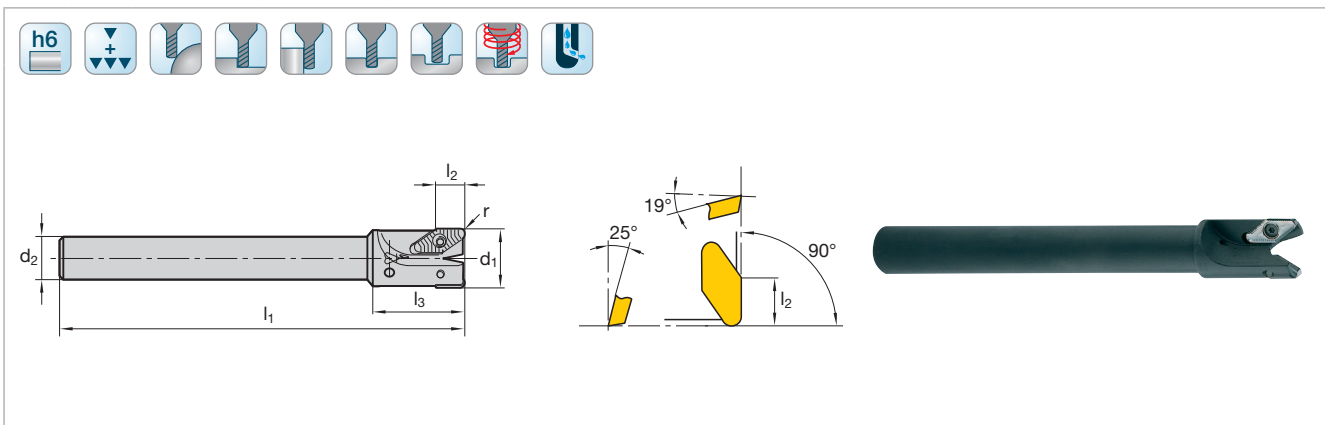

Katalog-Nr. Cat.-No.									EMZ 90 IK			
d ₁	r	l ₂	l ₁	l ₃	d ₂	z	Ident No.	LMT-Code				
25	1,2	13,5	200	40	20	2	1043243	EMZ90 V16.025AI-I	VPGT160412-ALM	1051312	1048335	
32	3	15	220	50	25	2	1043244	EMZ90 V22.032AG-I	VCGT 220530-ALM	1045766	T15	
42	3	15	220	50	25	3	1043245	EMZ90 V22.042AA-I				

Fräser auch verfügbar in Zoll-Abmessungen
 Cutters also available in inch dimensions

Schnittwertempfehlungen ab Seite 338
 Cutting data recommendations starting page 338