







Katalog-Nr. Cat.-No.								ERU90			
d <sub>1</sub>	l <sub>2</sub>	l <sub>1</sub>	l <sub>3</sub>	d <sub>2</sub>	z	Anzahl WSP Number of inserts	Ident No.	LMT-Code			
20	25	86	36	20	2	6	7097646	ERU90 A09.020BN-I	ADHX 09...	2127640	1048326 T8
25	33	100	44	25	2	8	7097647	ERU90 A09.025BN-I	ADKX 09...		
32	41	115	55	32	3	15	7097649	ERU90 A09.032BN-I			
32	45	115	55	32	2	8	7097651	ERU90 A12.032BN-I	ADHX 12...	2237513	
40	55	140	70	40	3	15	7097653	ERU90 A12.040BN-I	ADKX 12...		

Schnittwertempfehlungen ab Seite 196  
Cutting data recommendations starting page 196

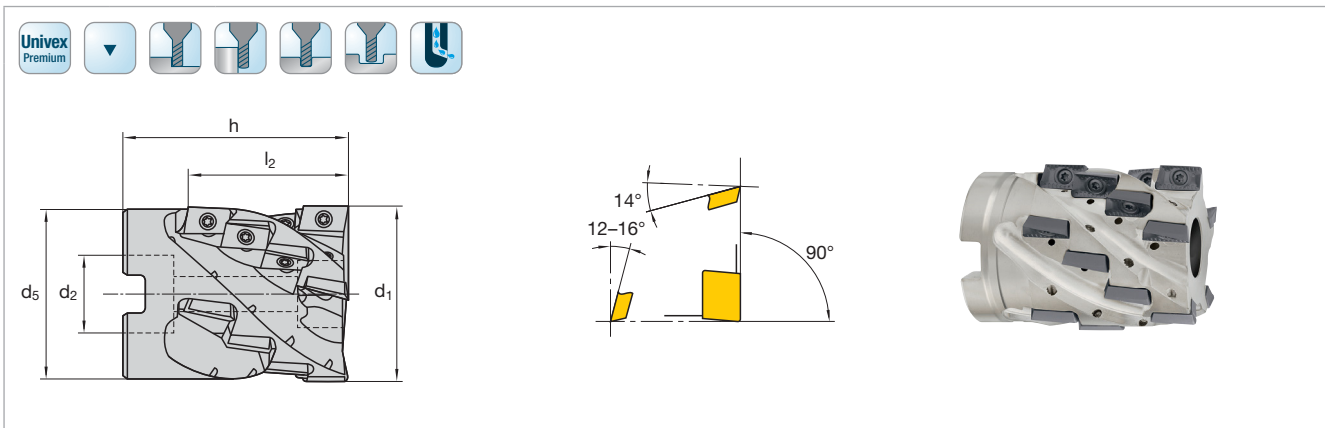
Univex Premium Walzenstirnfräser 90°  
Univex Premium Helical mill 90°



Katalog-Nr. Cat.-No.								FRU90			
d <sub>1</sub>	l <sub>2</sub>	h	d <sub>2</sub>	d <sub>5</sub>	z	Anzahl WSP Number of inserts	Ident No.	LMT-Code			
40	34	55	16	38	3	9	7097671	FRU90 A12.040AN-I	ADHX 12...	2237513	1048326 T8
50	45	65	22	48	4	16	7097672	FRU90 A12.050AN-I	ADKX 12...		
63	45	70	27	58	5	20	7097673	FRU90 A12.063AN-I			
63	48	70	27	58	4	12	7097674	FRU90 A17.063AN-I	ADHX 17...	1045114	1048335 T15
80	63	85	32	63	5	20	7097675	FRU90 A17.080AN-I	ADKX 17...		

Schnittwertempfehlungen ab Seite 196  
Cutting data recommendations starting page 196