

Katalog-Nr. Cat.-No.							FMU90 IK			
d <sub>1</sub>	l <sub>2</sub>	h	d <sub>5</sub>	d <sub>2</sub>	z	Ident No.	LMT-Code			
40	12	40	32	16	4	1045100	FMU90 A12.040AN-IW	ADHX 12... ADKX 12...	2237513	1048326 T8
40	12	40	32	16	6	1045101	FMU90 A12.040AN-I			
50	12	40	40	22	5	1045102	FMU90 A12.050AN-IW			
50	12	40	40	22	7	1045103	FMU90 A12.050AN-I			
63	12	40	50	22	6	1045104	FMU90 A12.063AN-IW			
63	12	40	50	22	9	1045106	FMU90 A12.063AN-I			

Fräser auch verfügbar in Zoll-Abmessungen  
Cutters also available in inch dimensions

Schnittwertempfehlungen ab Seite 196  
Cutting data recommendations starting page 196

Univex Premium Eckfräsköpfe 90°  
Univex Premium face milling cutters 90°

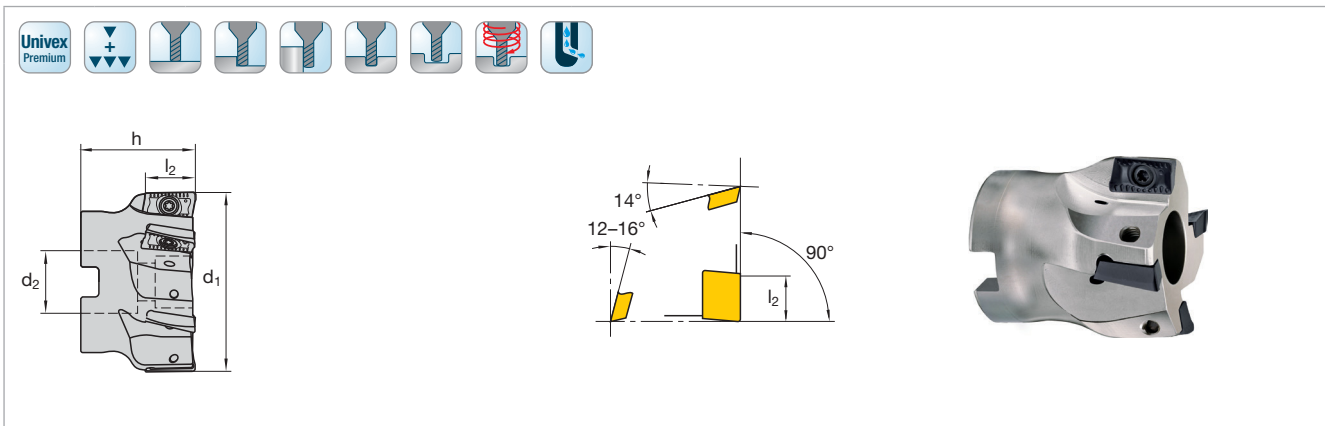

Katalog-Nr. Cat.-No.							FMU90 IK			
d <sub>1</sub>	l <sub>2</sub>	h	d <sub>2</sub>	z	Ident No.	LMT-Code				
40	16,5	36	16	4	1045035	FMU90 A17.040AN-IF	ADHX 17... ADKX 17...	1045114	1048335 T15	
50	16,5	40	22	5	1045036	FMU90 A17.050AN-IF				
63	16,5	40	22	6	1045037	FMU90 A17.063AN-IF				
80	16,5	50	27	8	1045038	FMU90 A17.080AN-IF				
100	16,5	50	32	9	1045039	FMU90 A17.100AN-IF				

Fräser auch verfügbar in Zoll-Abmessungen  
Cutters also available in inch dimensions

Schnittwertempfehlungen ab Seite 196  
Cutting data recommendations starting page 196